

Oblique Central Refraction in Spherocylindrical Corrections with Both Faceform and Pantoscopic Tilt

MICHAEL P. KEATING*

College of Optometry, Ferris State University, Big Rapids, Michigan

ABSTRACT

Thin lens equations, accurate to third order, are presented for the effective spherocylindrical parameters for oblique central refraction (OCR) through spherocylindrical lenses with both faceform and pantoscopic tilt. The equations can also be used to find the parameters of a lens that compensates for the tilts. Accuracy of the equations was checked by exact ray trace results.

Key Words: spherocylindrical lenses, oblique astigmatism, radial astigmatism, faceform tilt, pantoscopic tilt, oblique central refraction, dioptric power matrix

When a person looks through the optical center of a tilted spectacle lens at an object which is straight ahead, the effective spherocylindrical parameters of the lens can change as a result of the aberration variously called radial, marginal, or oblique astigmatism.¹ This situation is referred to as oblique central refraction (OCR). The effective spherocylindrical changes can become clinically significant for large enough tilt angles and high enough dioptric powers.

Third order thin lens equations describing OCR effects for tilted spherical lenses or for spherocylindrical lenses with either faceform or pantoscopic tilt around an axis (or principal) meridian have been known for a long time.² More recently, third order thin lens equations were published that also describe OCR effects for spherocylindrical lenses with either faceform or pantoscopic tilt around an off-axis (or nonprincipal) meridian.³ The latter situation occurs in the case of faceform or pantoscopic tilt of a spherocylindrical lens which has an oblique cylinder axis.

Table 1 shows 4 examples of the effective spherocylindrical changes for a lens with a 1.50 refractive index and a 15° faceform tilt. For case A, there is a slight gain in sphere power together with the appearance of a cylindrical component

greater than 0.25 D. For case B, there is approximately a 0.50 D increase in sphere power and a slightly more than 0.25 D decrease in cylinder power. For the oblique axis cases C and D, there is approximately a 0.25 D increase in the sphere power, a smaller increase in the cylinder power, and a 10° to 11° change in the effective cylinder axis.

Some sports frames have faceform tilt of the order of 15°. For large enough dioptric powers, when a lens matching the patient's prescription is placed in such a frame, the lens will appear to have poor optics because of the effective changes in the spherocylindrical parameters. However, the OCR effects can be compensated for by ordering a different lens such that the effective spherocylindrical parameters of the tilted lens match the patient's prescription. Table 2 shows the compensated lens parameters for the four patients listed in Table 1. In general, the compensated lens parameters can differ in sphere, cylinder, and/or axis from the untilted prescription.

The third order spherocylindrical equations previously published are for a lens with either pantoscopic or faceform tilt, but not both. Mounted lenses may well have both a faceform and a pantoscopic tilt, and this case is mathematically more complicated than that for a lens with just one of the tilts.

For a lens with both faceform and pantoscopic tilt, this paper presents OCR thin lens equations, accurate to third order, to calculate either the effective spherocylindrical parameters of the tilted lens, or to calculate the compensated lens parameters such that when the compensated lens is tilted, the effective spherocylindrical parameters match the prescription. The next section reviews the third order OCR equations for a spherocylindrical thin lens with either faceform or pantoscopic tilt. Then the additional equations needed for a lens with both faceform and pantoscopic tilt are presented, followed by some numerical results, and a discussion of the accuracy.

LENSES WITH EITHER FACEFORM OR PANTOSCOPIC TILT

For OCR, the tangential plane is the plane that contains the optical axis of the lens and the chief ray from the straight ahead object point, whereas

Received June 14, 1994; revision received January 5, 1995.

Preliminary work presented at the Annual Meeting of the American Academy of Optometry, Boston, Massachusetts, December, 1993

* Physicist, Ph.D., Member of Faculty, F.A.A.O.

TABLE 1. Third order calculated effective spherocylindrical parameters ($N = 1.50$) for oblique central refraction (OCR) in the case of a 15° faceform tilt.

Patient	Lens Prescription	Effective Parameters
A	-5.00	-5.11 -0.37 \times 90
B	-5.00 -1.00 \times 180	-5.48 -0.66 \times 180
C	-5.00 -1.00 \times 47	-5.25 -1.16 \times 57.2
D	-5.00 -1.00 \times 140	-5.29 -1.07 \times 129

TABLE 2. Third order calculated compensated lenses ($N = 1.50$) for a 15° faceform tilt.^a

Patient	Compensated Lens	Effective Parameters
A	-4.56 -0.33 \times 180	-5.00
B	-4.56 -1.31 \times 180	-5.00 -1.00 \times 180
C	-4.71 -0.99 \times 36.3	-5.00 -1.00 \times 47
D	-4.67 -1.07 \times 149.7	-5.00 -1.00 \times 140

^a Patients are the same as in Table 1. Under OCR conditions, the effective spherocylindrical parameters of the compensated lens match the patients' prescription.

the sagittal plane is the plane that contains the chief ray and is perpendicular to the tangential plane. For faceform tilt and a straight ahead object point, the tangential plane is horizontal and the sagittal plane is vertical. For pantoscopic tilt and a straight ahead object point, the tangential plane is vertical and the sagittal plane is horizontal. These assignments are the same for either the right or the left spectacle lens.

The 2×2 dioptric power matrix formalism has turned out to be a very useful tool for analyzing spherocylindrical lens systems, and has also served as the stimulus for the further development of spherocylindrical mathematical and statistical methods.⁴⁻¹⁸ For faceform or pantoscopic tilt of any spherocylindrical lens, including those with oblique axes, the thin lens third order equations for the effective lens parameters are easily stated in terms of a 2×2 dioptric power matrix expressed in a horizontal and vertical coordinate system.

Consider a spherocylindrical lens with standard parameters S C \times θ . The dioptric power matrix \mathbf{P} of this lens as expressed in a horizontal x and vertical y coordinate system is given by equations 1 to 4.⁴

$$\mathbf{P} = \begin{pmatrix} P_x & P_t \\ P_t & P_y \end{pmatrix}, \quad (1)$$

where

$$P_x = S + C \sin^2 \theta, \quad (2)$$

$$P_y = S + C \cos^2 \theta, \quad (3)$$

and

$$P_t = -C \sin \theta \cos \theta. \quad (4)$$

Here P_x is the dioptric power curvature component in the horizontal meridian, P_y is the dioptric power curvature component in the vertical merid-

ian, and P_t is the dioptric power torsional component in both the horizontal and vertical meridians.

Conversely given a dioptric power matrix, the lens spherocylindrical parameters are found as follows.^{5, 10} When P_t is zero, P_x and P_y are just the horizontal and vertical principal meridian powers, and the spherocylindrical parameters can be computed from the matrix with a normal power cross procedure. When P_t differs from zero, the spherocylindrical parameters of the lens can be found from the matrix by use of the following equations.

$$C = \pm (t^2 - 4d)^{1/2}, \quad (5)$$

$$S = (t - C)/2, \quad (6)$$

and

$$\theta = \tan^{-1} [(S - P_x)/P_t], \quad (7)$$

where t is the trace of the matrix \mathbf{P} ,

$$t = P_x + P_y, \quad (8)$$

and d is the determinant of the matrix \mathbf{P}

$$d = P_x P_y - P_t^2. \quad (9)$$

For a second quadrant axis, equation 7 returns a negative value for θ . This can be converted to standard axis notation by adding 180 to θ .

For OCR, let S_e $C_e \times \theta_e$ be the effective spherocylindrical parameters of a tilted lens. There is a corresponding effective dioptric power matrix \mathbf{ER} expressed in the horizontal x and vertical y coordinate system,

$$\mathbf{ER} = \begin{pmatrix} E_x & E_t \\ E_t & E_y \end{pmatrix}, \quad (10)$$

with the usual relations, equations 2 to 9, between the matrix elements and the effective spherocylindrical parameters.

For a lens with refractive index n and a faceform tilt angle ϕ , the elements of the effective dioptric power matrix \mathbf{ER} are related to the elements of the lens dioptric power matrix \mathbf{P} by the equations:³

$$\mathbf{ER} = \begin{pmatrix} P_x T_c & P_t H_c \\ P_t H_c & P_y S_c \end{pmatrix} \quad (11)$$

where

$$T_c = \frac{2n + \sin^2 \phi}{2n \cos^2 \phi}, \quad (12)$$

$$S_c = 1 + \frac{\sin^2 \phi}{2n}, \quad (13)$$

and

$$H_c = (T_c + S_c)/2. \quad (14)$$

Here T_c is the effective change factor for the dioptric power curvature component in the tangential meridian (which for faceform tilt is P_x), S_c is the effective change factor for the dioptric power curvature component in the sagittal meridian (which for faceform tilt is P_y), and H_c is the effective change factor for the torsional components (P_t).

The OCR results in Table 1 were obtained by using equations 1 to 14 in the forward direction to calculate the effective spherocylindrical parameters of a tilted lens. The OCR results in Table 2 were obtained by using equations 1 to 14 in the "reverse" direction to calculate the compensated lens parameters.

For a lens with a pantoscopic tilt, the tangential and sagittal meridians are still horizontal and vertical, but are the opposite of those for faceform tilt. Therefore S_c and T_c in equation 11 must be interchanged. Let EL be the effective dioptric power matrix for pantoscopic tilt, and replace equation 11 with

$$EL = \begin{pmatrix} P_x S_c & P_t H_c \\ P_t H_c & P_y T_c \end{pmatrix}. \quad (15)$$

The rest of the equations are the same for either pantoscopic or faceform tilt.

LENSES WITH BOTH FACEFORM AND PANTOSCOPIC TILT

In the more complicated case of OCR for a spectacle lens with both faceform and pantoscopic tilt, there is an effective tilt angle ϕ that is a function of the faceform tilt angle f and the pantoscopic tilt angle p . Also, the tangential and sagittal planes are no longer horizontal and vertical. Furthermore, because pantoscopic tilt is in the same direction for either the right or the left eye, whereas faceform tilt is in the opposite direction for the

right vs. the left eye, the symmetry is broken and the right and left cases have to be treated in a slightly different manner. Finally, the vertical meridian in the local coordinate system of the tilted lens is not aligned with the vertical meridian of the eye, and this must be taken into account in the calculations.

Because the tangential and sagittal meridians are no longer horizontal and vertical, we will need to express the dioptric power matrix and the effective dioptric power matrix in a coordinate system that is rotated clockwise or counterclockwise from horizontal and vertical. Fig. 1 shows an x_A and y_A coordinate system which is rotated counterclockwise by an angle A from the horizontal and vertical (x, y) coordinate system. For a spherocylindrical lens with effective parameters of $S_e C_e \times \theta_e$ in standard axis notation, the axis angle θ_e is the angle as measured from the horizontal or x axis. In Fig. 1, the cylinder axis makes the angle θ_A with the x_A axis, where

$$\theta_e = \theta_A + A. \quad (16)$$

When used in equations 1 to 4, the parameters $S_e C_e \times \theta_e$ return the dioptric power matrix as expressed in the horizontal and vertical x, y coordinate system, whereas the parameters $S_e C_e \times \theta_A$ return the dioptric power matrix as expressed in the x_A, y_A coordinate system.

Fig. 2 shows the OCR geometry for a right spectacle lens. The straight ahead position for the eye is the z axis. For a centered spectacle lens, the z axis also passes through the optical center of the spectacle lens. The coordinate system in the back (or upper right in the figure) is the system aligned with an eye looking straight ahead along the z axis. The horizontal meridian is x and the vertical meridian is y . The coordinate systems in the front (or lower left in the figure) are at the position of

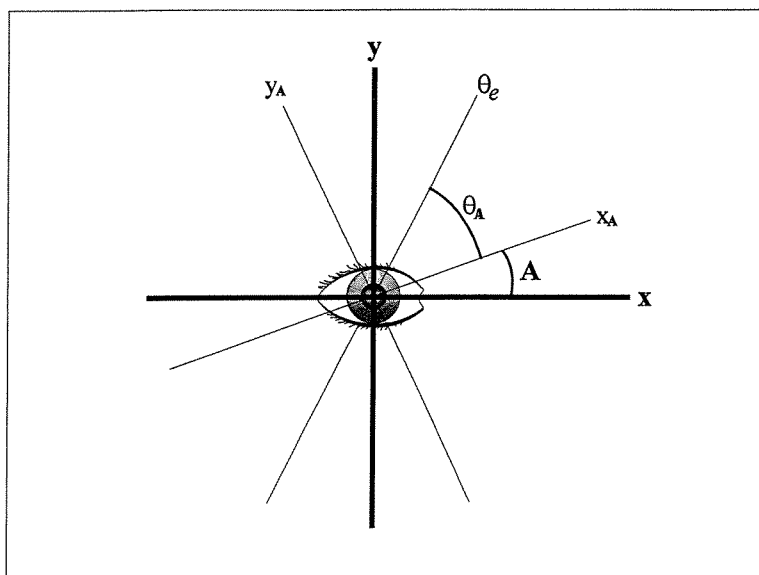

Figure 1. View facing the patient of an untilted horizontal and vertical (x, y) coordinate system aligned with the right eye. The x_A, y_A coordinate system is rotated counterclockwise through the angle A . The line labeled θ_e is the (effective) cylinder axis in standard axis notation relative to the x axis. The effective cylinder axis makes the angle θ_A with the x_A axis.

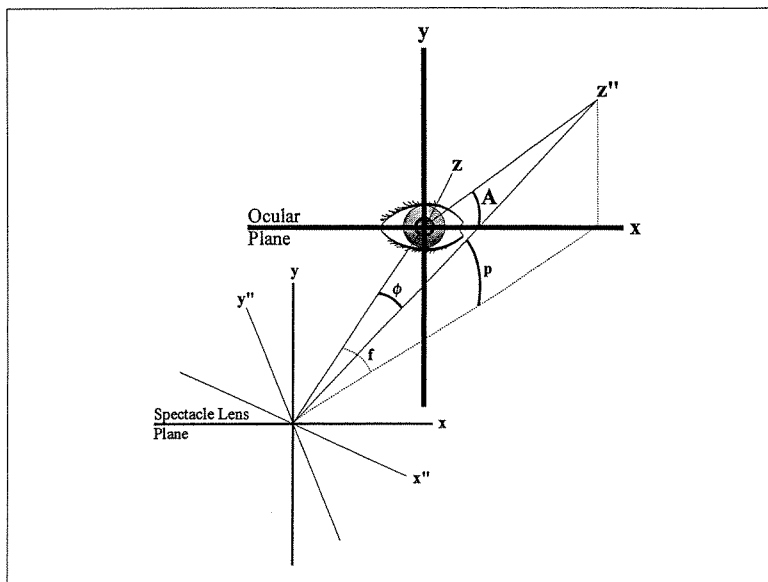

Figure 2. In the ocular plane is the un-tilted horizontal and vertical (x, y) coordinate system aligned with the right eye. The z axis is the straight ahead position and passes through the origin of the coordinate system in the spectacle plane. When un-tilted, the spectacle lens is aligned with the spectacle plane x, y, z coordinate system. When the spectacle lens has a faceform tilt of angle f (rotation about y) and a pantoscopic tilt of angle p (rotation about x''), it is aligned with the x'', y'', z'' coordinate system, and ϕ is the effective tilt angle. The ocular tangential meridian as expressed in the un-tilted x, y, z coordinate system lies at the angle A with respect to the x axis.

the spectacle lens. When un-tilted, the optical axis of the spectacle lens lies along the z axis, and the horizontal and vertical meridians of the lens are, respectively, aligned with the x and y axes.

The faceform tilt of angle f is equivalent to a rotation of the spectacle lens around the vertical or y meridian. The faceform tilted lens would have a local coordinate system (not shown) of $x', y',$ and z' , where y' is identical to y and (for reasons given below) x' is identical to x'' . The pantoscopic tilt of angle p is equivalent to a rotation of the lens around the local x' meridian. The resulting local coordinate system of the lens is x'', y'', z'' (where x'' is identical to x'), and the optical axis of the lens now lies along z'' .

The local x'', y'', z'' coordinate system is related to the un-tilted x, y, z coordinate system by the Euler rotation matrix as is commonly used in classical mechanics or engineering.¹⁹ (The Euler rotation matrix has also been used in descriptions of three-dimensional eye movements.²⁰) It is important to note that the local vertical meridian of the lens (y'') is not aligned with the vertical meridian (y) of the eye.

The effective tilt angle ϕ of the lens is the angle between z'' and z . From the geometry, ϕ is given by

$$\tan \phi = (\sin^2 f + \tan^2 p)^{1/2} / \cos f. \quad (17)$$

For OCR in the case of the right spectacle lens with both a faceform and a pantoscopic tilt, the local tangential meridian of the tilted lens will be a first quadrant meridian and the local sagittal meridian will be the perpendicular second quadrant meridian. (Second quadrant meridians are those that in standard axis notation lie at an angle greater than 90° with the x axis, whereas first quadrant meridians lie at an angle less than 90° with the x axis.) The geometry of Fig. 2 shows

that in the un-tilted x, y plane aligned with the eye, the tangential meridian lies at an angle A relative to the x axis, where A is given by

$$\tan A = \tan p / \sin f. \quad (18)$$

In the local coordinate system of the right tilted lens, the tangential meridian will make an angle of A'' with the local horizontal axis x'' . Because the local vertical meridian y'' of the tilted lens is not lined up with the vertical meridian y of the eye, A'' will differ from A . The geometry in the local coordinate system shows that

$$\tan A'' = \sin p / \tan f. \quad (19)$$

For the left lens (not shown), the tangential meridians are second quadrant meridians, and the sagittal meridians are first quadrant meridians. There are several possible ways to take this into account. One way is to let A and A'' always be the angles for the first quadrant meridian (tangential for the right eye and sagittal for the left eye). Then for the left eye, A and A'' are first computed from equations 18 and 19, and then redefined (in the sense of a programming equation) as

$$A = 90 - A \text{ (left only)}, \quad (20)$$

and

$$A'' = 90 - A'' \text{ (left only)}. \quad (21)$$

Fig. 3 shows the local x'', y'' plane. Normal lens-meter procedures measure the spherocylindrical parameters $S'' C'' x \theta''$ in this coordinate system. In order to calculate the effective spherocylindrical parameters of the tilted lens, we need to know the lens dioptric power matrix not as expressed in the x'', y'' system, but rather as expressed in a local coordinate system which is aligned with the local

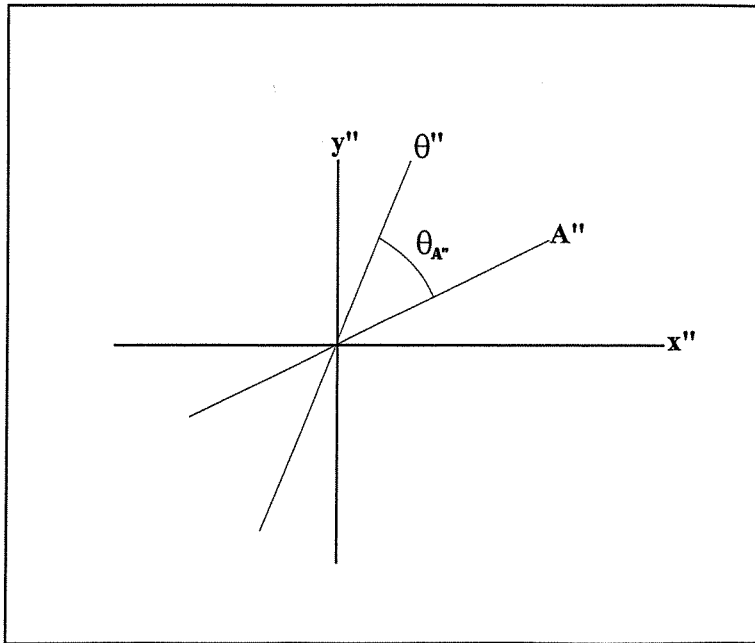

Figure 3. Angles as expressed in the (local) x'' , y'' coordinate system of the tilted right spectacle lens. θ'' is the cylinder axis meridian, whereas A'' is the tangential meridian, both measured with respect to the x'' axis. The cylinder axis makes the angle $\theta_{A''}$ with the tangential meridian.

tangential (A'') and sagittal meridians ($A'' \pm 90^\circ$) of the tilted lens. In Fig. 3, the cylinder axis θ'' of the lens makes an angle $\theta_{A''}$ relative to the tangential meridian, where

$$\theta_{A''} = \theta'' - A'' \quad (22)$$

One can use the parameters $S C \times \theta_{A''}$ in equations 1 to 4 to compute the dioptric power matrix \mathbf{P}'' , as expressed in the local tangential and sagittal meridians of the tilted lens.

For the right lens, the first row-first column element of \mathbf{P}'' is the dioptric power curvature component in the tangential meridian, and the second row-second column element is the dioptric power curvature component in the sagittal meridian. These are opposite for the left lens. Therefore we can use equation 11 to compute the effective dioptric power matrix \mathbf{ER} for the right lens and equation 15 to compute the effective dioptric power matrix \mathbf{EL} for the left lens.

From either effective matrix, we can then use equations 5 and 6 to compute the effective sphere S_e and cylinder C_e power parameters of the tilted lens and equation 7 to find the effective axis θ_A relative to the untilted tangential and sagittal meridians aligned with the eye (see Fig. 1). Then from equations 18, 20, and 16, we can find the effective cylinder axis θ_e in standard notation.

NUMERICAL RESULTS

As an example, consider a $-5.00 -1.00 \times 180$ lens for the right eye. For a 15° faceform tilt and a 10° pantoscopic tilt, equation 17 gives a 17.96° effective tilt angle ϕ . From equation 19, $A'' = 32.95^\circ$, which is the tangential meridian expressed in the lens' local coordinate system. From equation 18, $A = 34.27^\circ$, which is the tangential

meridian expressed in the coordinate system that is aligned with the eye (or with an untilted lens). From equation 22, the cylinder axis expressed in the local coordinate system aligned with the lens' tangential and sagittal meridian equals 147.05° (from 180° minus 32.95°). Then from equations 1 to 4 for a $-5.00 -1.00 \times 147.05$ lens,

$$\mathbf{P}'' = \begin{pmatrix} -5.296 & -0.456 \\ -0.456 & -5.704 \end{pmatrix}$$

From equations 11 to 14, the effective dioptric power matrix \mathbf{ER} as expressed in the untilted coordinate system aligned with the tangential and sagittal meridians is then given by:

$$\mathbf{ER} = \begin{pmatrix} (-5.296) (1.140) & (-0.456) (1.086) \\ (-0.456) (1.086) & (-5.704) (1.032) \end{pmatrix}$$

or

$$\mathbf{ER} = \begin{pmatrix} -6.038 & -0.496 \\ -0.496 & -5.885 \end{pmatrix}$$

From equations 5 and 6, the effective sphere power is -5.460 D and the effective cylinder power is -1.003 D, whereas equation 7 returns a 130.62 axis relative to A. Equation 16 then gives 164.9 as the cylinder axis in standard notation. Thus $-5.46 -1.00 \times 164.9$ are the effective spherocylindrical parameters of a $-5.00 -1.00 \times 180$ lens with a 15° faceform tilt and a 10° pantoscopic tilt. (The appendix contains a flow chart for the equations used to calculate the effective spherocylindrical parameters.)

For the same cases presented in Tables 1 and 2, Table 3 presents the calculated effective spherocylindrical parameters for OCR when the right lens has a 15° faceform tilt and a 10° pantoscopic

TABLE 3. For the right eye, calculated third order effective parameters ($n = 1.50$) for OCR in the case of a lens 15° faceform and a 10° pantoscopic tilt.^a

Patient	Lens Prescription	Effective Parameters
A	-5.00	-5.16 -0.54 × 124.3
B	-5.00 -1.00 × 180	-5.46 -1.00 × 164.9
C	-5.00 -1.00 × 47	-5.64 -0.63 × 61.6
D	-5.00 -1.00 × 140	-5.19 -1.61 × 135.3

^a Patients are the same as in Table 1.

tilt. (Case B is the example just worked out.) These results can be compared to those of Table 1 to see the effects of the pantoscopic tilt in the presence of faceform tilt. A comparison shows that for cases A and B, there are fairly large cylinder axis changes. In cases C and B, the more dominant changes are in the power parameters (0.25 D to 0.50 D differences).

Given the patient's (untilted) prescription and a frame with both faceform and pantoscopic tilt, one can use equations 1 to 22 in the reverse direction to compute the parameters of the lens that compensates for the tilt. (The appendix contains a flow chart for the equations needed together with a numerical example.) For the same prescriptions shown in Tables 1 to 3, Table 4 shows the compensated lens results for right and left lenses, each with a 15° faceform tilt and a 10° pantoscopic tilt. For the right lens, a comparison of Tables 2 and 4 shows the effects on the compensated lens of taking into account the pantoscopic tilt together with the faceform tilt.

Given the same prescription, Table 4 also shows that if one were to compensate for both the faceform and pantoscopic tilt, then the compensated lens parameters are different for the right and the left lenses. In cases A and B, the power parameters of the compensated left and right lens are about the same, but the cylinder axes are significantly different. For cases C and D, the principal meridians of the untilted prescription are much closer to the tangential and sagittal meridians of the tilted lens. Here, the cylinder axes of the right and left compensated lenses are much closer to each other, but there are significant differences in sphere and cylinder powers.

ACCURACY

Just as in reference 3, the accuracy of the third order thin lens matrix method was checked by

TABLE 4. The calculated compensated lens ($n = 1.50$) parameters, for OCR in the case of a lens 15° faceform and a 10° pantoscopic tilt.^a

Patient	Right Compensated Lens	Left Compensated Lens
A	-4.39 -0.46 × 32.9	-4.39 -0.46 × 147.1
B	-4.48 -1.20 × 10.2	-4.48 -1.20 × 169.8
C	-4.40 -1.40 × 41.2	-4.82 -0.46 × 38.8
D	-4.78 -0.56 × 152.8	-4.39 -1.42 × 143.4

^a Effective parameters of the compensated lenses match the prescription; patients are the same as in Tables 1 to 3.

exact ray trace calculations using BEAM4, a commercially available ray trace program. For the calculations here, the thin lens OCR conditions were simulated by specifying a 1-mm lens diameter and a 0.01-mm central thickness.

An example of the accuracy for a right -5.00 -1.00 x 47 lens is shown in Table 5, where the third order method matches the exact results for effective tilt angles up to about 20° . As the tilt angles are increased further, the third order method slowly starts to lose accuracy. For a 30° faceform tilt and a 20° pantoscopic tilt, the effective tilt angle ϕ is 35.5° , which is in the vicinity of the limits of accuracy for third order equations. Here the third order spherical power still differs from the exact ray trace result by only 0.14 D (or 2.1%), the cylinder power differs by only 0.03 D, and the cylinder axis differs by 0.2° . The dioptric power dependence is much weaker than the tilt angle dependence, so the limits here are fairly general.

For real lenses with actual thickness, the OCR third order thin lens equations are a good approximation for thinner lenses, and slowly start to lose accuracy for thicker lenses. Table 6 shows a comparison of the third order thin equations vs. an exact ray trace for a fairly thick lens. The lens parameters are: +6.00 -1.00 x 47 back vertex power, 7-mm central thickness, +12.00 D front surface, -6.71 -1.00 x 47 back surface, 1.50 refractive index. For a 15° faceform and a 10° pantoscopic tilt, the effective tilt angle is 17.96° and the thin lens effective parameters are all within the ANSI Z80.1 standards of the exact thick lens results.²¹ For smaller tilt angles, the third order results are more accurate. As the tilt angles increase, the third order thin lens results slowly start to deviate from the exact thick lens results. For a 21° faceform and a 14° pantoscopic tilt, the effective tilt angle is 25° , and the thin lens effective parameters differ by 0.20 D in the spherical component (2.9%), 0.03 D in the cylindrical component, and 6.3° in the cylinder axis. In this case, it appears that the thin lens equations work well for effective tilt angles up to approximately 20° , which is well within the range of frames even with "large" tilts.

The previous example was for a lens with plus power in both principal meridians, and so the thickest part of the lens is at the optical center.

TABLE 5. Comparison of calculated effective spherocylindrical parameters for a right -5.00 -1.00 × 47 lens ($n = 1.50$); the faceform angle is f and the pantoscopic angle is p (both in degrees).

f	p	Third Order	Exact
0	0	-5.00 -100 × 47.0	-5.00 -1.00 × 47.0
15	10	-5.64 -0.63 × 61.6	-5.64 -0.63 × 61.6
18	12	-5.88 -0.55 × 74.6	-5.90 -0.55 × 74.5
24	16	-6.26 -0.93 × 104.1	-6.32 -0.93 × 104.1
30	20	-6.52 -2.09 × 115.5	-6.66 -2.12 × 115.7

TABLE 6. Comparison of calculated OCR effective lens parameters ($n = 1.50$) for a 7-mm thick $+6.00 - 1.00 \times 47$ lens ($n = 1.50$) with a $+12.00$ D front surface and a $-6.71 - 1.00 \times 47$ back surface.

f	p	Thin Lens Third Order	Thick Lens Exact
0	0	$+6.00 - 1.00 \times 47.0$	$+6.00 - 1.00 \times 47.0$
15	10	$+6.23 - 0.56 \times 35.0$	$+6.29 - 0.53 \times 35.8$
18	12	$+6.37 - 0.43 \times 21.3$	$+6.47 - 0.40 \times 17.0$
21	14	$+6.65 - 0.47 \times 178.8$	$+6.85 - 0.50 \times 172.5$

On the other hand, minus lenses are thinnest at the optical center. Therefore for the same power magnitude, the third order thin lens results for minus lenses will be more accurate than those for plus lenses.

The calculations here were obtained for the case where the faceform tilt is a rotation around the vertical axis (y in Fig. 2), and the pantoscopic tilt is then a rotation around the local horizontal axis. It is well-known that rotations commute for small (first order) angles, but do not commute for large angles. Therefore, if the order of the tilts is intentionally reversed, so that the "pantoscopic" tilt is a tilt around the horizontal axis x , and the "faceform" tilt is then a tilt around the local vertical meridian, the results would not change significantly if at least one of the tilts is a first order angle. However, if both tilts are third order angles, then the geometric orientation of the lens would be slightly different than that presented here, and consequently the effective spherocylindrical parameters would also be slightly different.

Third order equations have been presented that take into account thickness for the case of spherocylindrical lenses with a single tilt around a principal meridian.²² Whether or not it is possible to extend the third order thickness equations to the case of spherocylindrical lenses with both faceform and pantoscopic tilt remains to be investigated.

CONCLUSION

For spherocylindrical lenses with both faceform and pantoscopic tilt, equations 1 to 22 present thin lens OCR equations, accurate to third order, to compute either the effective spherocylindrical parameters of the tilted lens or, given a patient's prescription, to compute the compensated lens parameters (such that when the compensated lens is tilted, the effective spherocylindrical lens parameters match the patient's prescription). Some sports frames have tilts of the order of 15° and, for these tilts, the thin lens OCR equations appear to be good approximations to the exact thick lens results.

There are instances where the compensation for faceform tilt (only) has improved the optics of sports vision lenses. This paper has not discussed whether clinically one would want to compensate for both faceform and pantoscopic tilt. Rather this paper simply presents the equations needed so

that a full investigation and informed decision can be made.

For those people already familiar with the dioptric power matrix formalism, the OCR equations are particularly easy to use. The equations are also easy to program, either on a hand-held calculator or on a microcomputer, and can then be used by all in a "user friendly" manner.

APPENDIX

Flow Chart for Equations Needed to Find the Effective Spherocylindrical Parameters $S_e C_e \times \theta_e$ of a Lens with Faceform Tilt f and Pantoscopic Tilt p

Let $S'' C'' \times \theta''$ be the parameters of the lens as typically measured (i.e., in the local coordinate system of the lens).

Find the effective tilt angle ϕ from equation 17.

Use equations 12 to 14 to find T_c, S_c, H_c .

Use equation 19 to find A'' . If the lens is for a left eye, use equation 21 to modify A'' .

Find $\theta_{A''}$ from equation 22.

Use equations 1 to 4 to find the dioptric power matrix P'' that corresponds to $S'' C'' \times \theta_{A''}$. (These are the lens parameters as expressed in the local tangential and sagittal meridians of the lens.)

From P'' use equation 11 (right lens) or equation 15 (left lens) to find the effective dioptric power matrix ER or EL as expressed in the tangential and sagittal meridians of the eye.

From either ER or EL , use equations 5 to 9 to find $S_e C_e \times \theta_A$. (These are the effective spherocylindrical parameters of the lens as expressed in a coordinate system aligned with the sagittal and tangential meridians of the eye.)

Find A from equation 18. If this is the left lens, use equation 20 to modify A .

Find θ_e from equation 16. The effective spherocylindrical parameters of the tilted lens are $S_e C_e \times \theta_e$.

Flow Chart for Equations Needed to Find the Spherocylindrical Parameters $S'' C'' \times \theta''$ of a Lens Compensated for a Faceform Tilt f and a Pantoscopic Tilt p

Set the effective spherocylindrical parameters $S_e C_e \times \theta_e$ of the tilted compensated lens equal to the patient's prescription.

From the faceform tilt f and pantoscopic tilt p , use equation 17 to find the effective tilt angle ϕ .

Use equations 12 to 14 to find T_c, S_c, H_c .

Use equation 18 to find A . If the lens is for the left eye, use equation 20 to modify A .

Use equation 16 to find θ_A .

From $S_e C_e \times \theta_A$, use equations 1 to 4 to compute the elements of the effective dioptric power matrix as expressed in the tangential and sagittal meridians aligned with the eye. When the lens is for the right eye, call this matrix ER . When the lens is for the left eye, call this matrix EL .

Divide each element of **ER** or **EL** by the appropriate factor T_c , S_c , or H_c listed in equations 11 (right eye) or 15 (left eye) to find **P''** the dioptric power matrix for the compensated lens as expressed in its local tangential and sagittal meridians.

From **P''**, use equations 5 to 9 to find $S'' C'' \times \theta_{A''}$.

Find A'' from equation 19. If the lens is for the left eye, use equation 21 to modify A'' .

Use equation 22 to find θ'' . The compensated lens has spherocylindrical parameters of $S'' C'' \times \theta''$.

Numerical Example to Find a Compensated Lens

A patient's prescription for the left eye is $-5.00 -1.00 \times 140$. The frame will have a 15° faceform tilt and a 10° pantoscopic tilt. Find the compensated lens ($n = 1.50$) parameters. (These are the numbers for the left lens for patient D of Table 4.)

From equation 17, $\phi = 17.96^\circ$.

From equations 12 to 14, $T_c = 1.140$, $S_c = 1.032$, and $H_c = 1.086$.

From equation 18, $A = 34.27^\circ$; because this is the left eye, equation 20 gives $A = 55.73^\circ$.

From equation 16, $\theta_A = 140^\circ - 55.73^\circ = 84.27^\circ$.

The desired effective spherocylindrical parameters expressed in the tangential and sagittal meridians of the eye are then $-5.00 -1.00 \times 84.27$, and then equations 1 to 4 give the effective dioptric power matrix **EL** for the left eye.

$$\mathbf{EL} = \begin{pmatrix} -5.990 \text{ D} & +0.099 \text{ D} \\ +0.099 \text{ D} & -5.010 \text{ D} \end{pmatrix}.$$

From equation 15,

$$\mathbf{P}'' = \begin{pmatrix} -5.990 \text{ D}/1.032 & +0.099 \text{ D}/1.086 \\ +0.099 \text{ D}/1.086 & -5.010 \text{ D}/1.140 \end{pmatrix},$$

or

$$\mathbf{P}'' = \begin{pmatrix} -5.804 \text{ D} & +0.092 \text{ D} \\ +0.092 \text{ D} & -4.395 \text{ D} \end{pmatrix}.$$

Then from equations 5 to 9, $-4.389 -1.421 \times 86.30$ are the spherocylindrical parameters as expressed in the local tangential and sagittal meridians of the lens.

From equation 19, $A'' = 32.946^\circ$; because this is a left lens equation 21 gives $A'' = 57.054^\circ$.

Then equation 22 gives $\theta'' = 143.35^\circ$, and $-4.389 -1.421 \times 143.35$ are the compensated lens parameters.

REFERENCES

- Kuether CL. In: Tasman W, Jaeger EA, ed. *Duane's Clinical Ophthalmology*, chapter 32. Philadelphia: JB Lippincott, 1991:69.
- Jalie M. *The Principles of Ophthalmic Lenses*. London: Association of Dispensing Opticians, 1984:402-4.
- Keating MP. Oblique central refraction in spherocylindrical lenses tilted around an off-axis meridian. *Optom Vis Sci* 1993;70:785-91.
- Long WF. A matrix formalism for decentration problems. *Am J Optom Physiol Opt* 1976;53:27-33.
- Keating MP. An easier method to obtain the sphere, cylinder, and axis from an off-axis dioptric power matrix. *Am J Optom Physiol Opt* 1980;57:734-7.
- Keating MP. Advantages of a block matrix formulation for an astigmatic system. *Am J Optom Physiol Opt* 1982;59:851-7.
- Keating MP. A matrix formulation for spectacle magnification. *Ophthal Physiol Opt* 1982;2:145-58.
- Keating MP. The aniseikonic matrix. *Ophthal Physiol Opt* 1982;2:193-204.
- Keating MP. On the use of matrices for the mean value of refractive errors. *Ophthal Physiol Opt* 1983;3:201-3.
- Keating MP. *Geometric, Physical, and Visual Optics*. Boston: Butterworths-Heinemann, 1980:329-53.
- Harris WF. Algebra of spherocylinders and refractive errors, and their means, variance, and standard deviation. *Am J Optom Physiol Opt* 1988;65:794-802.
- Harris WF. Statistical inference on mean dioptric power: hypothesis testing and confidence regions. *Ophthal Physiol Opt* 1990;10:363-72.
- Harris WF. Representation of dioptric power in Euclidean 3-space. *Ophthal Physiol Opt* 1991;11:130-6.
- Harris WF, Malan DJ, Rubin A. The distribution of dioptric power: ellipsoids of constant probability density. *Ophthal Physiol Opt* 1991;11:381-4.
- Harris WF, Malan DJ, Rubin A. Ellipsoidal confidence regions for mean refractive status. *Optom Vis Sci* 1991;68:950-3.
- Deal FC Jr, Toop J. Recommended coordinate systems for thin spherocylindrical lenses. *Optom Vis Sci* 1993;70:409-13.
- Harris WF. Astigmatic optical systems with separated and prismatic or noncoaxial elements: system matrices and system vectors. *Optom Vis Sci* 1993;70:545-51.
- Harris WF. Keating's asymmetric dioptric power matrices expressed in terms of sphere, cylinder, axis, and asymmetry. *Optom Vis Sci* 1993;70:666-7.
- Goldstein H. *Classical Mechanics*. Reading: Addison Wesley, 1980:143-8.
- Clement RA. *Introduction to Vision Science*. Hove: Lawrence Erlbaum Associates Ltd., 1993:172-88.
- ANSI Z80.1-1979. *American National Standard Recommendations for Prescription Ophthalmic Lenses*. American National Standards Institute: Washington, 1979:10.
- Illueca C, Hernandez C, Domenech B. Focimeter measurement of the astigmatism arising from oblique central refraction. *Ophthal Physiol Opt* 1992;12:52-7.

AUTHOR'S ADDRESS:

Michael P. Keating
College of Optometry, PEN 401
Ferris State University
1310 Cramer Circle
Big Rapids, Michigan 49307-2738